

NOTES:

1. BOX SIZE:
 - A. WIDTH: 20.75"
 - B. LENGTH: 24.75"
 - C. HEIGHT: 10.0"
2. BOXED UNIT GROSS WEIGHT:
3. SERIAL LABEL INFORMATION:
 - A. SKU: 700-0507-XX (-XX SPECIFIED IN P.O.)
 - B. SERIAL NUMBER: PER DOC 622-200-110
 - C. MANUFACTURING DATE: MM/DD/YY
4. APPLY BOX LABEL (4X) WITH THE FOLLOWING INFORMATION:
 - A. MODEL: KIT, DISPLAY, 10IN TOUCHSCREEN, 4-CT/UB/RB
 - B. SKU: 700-0507-XX (-XX SPECIFIED IN P.O.)
 - C. SERIAL NUMBER (SAME AS SERIAL LABEL)
 - D. SKU AND SERIAL NUMBER BAR CODE (CODE 128)
5. COLOR DESIGNATOR PER -XX AS SPECIFIED IN PARENT SKU, -XX COLOR PER SOP 622-200-112

REVISION HISTORY

REV	DATE	DESCRIPTION	ECO	BY
A	4/29/2020	PRODUCTION RELEASE	20059	ZDH

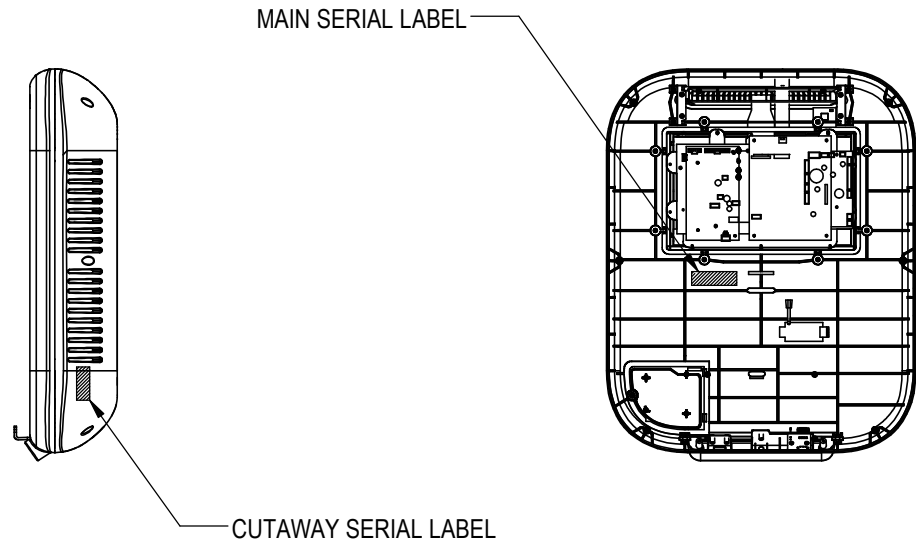
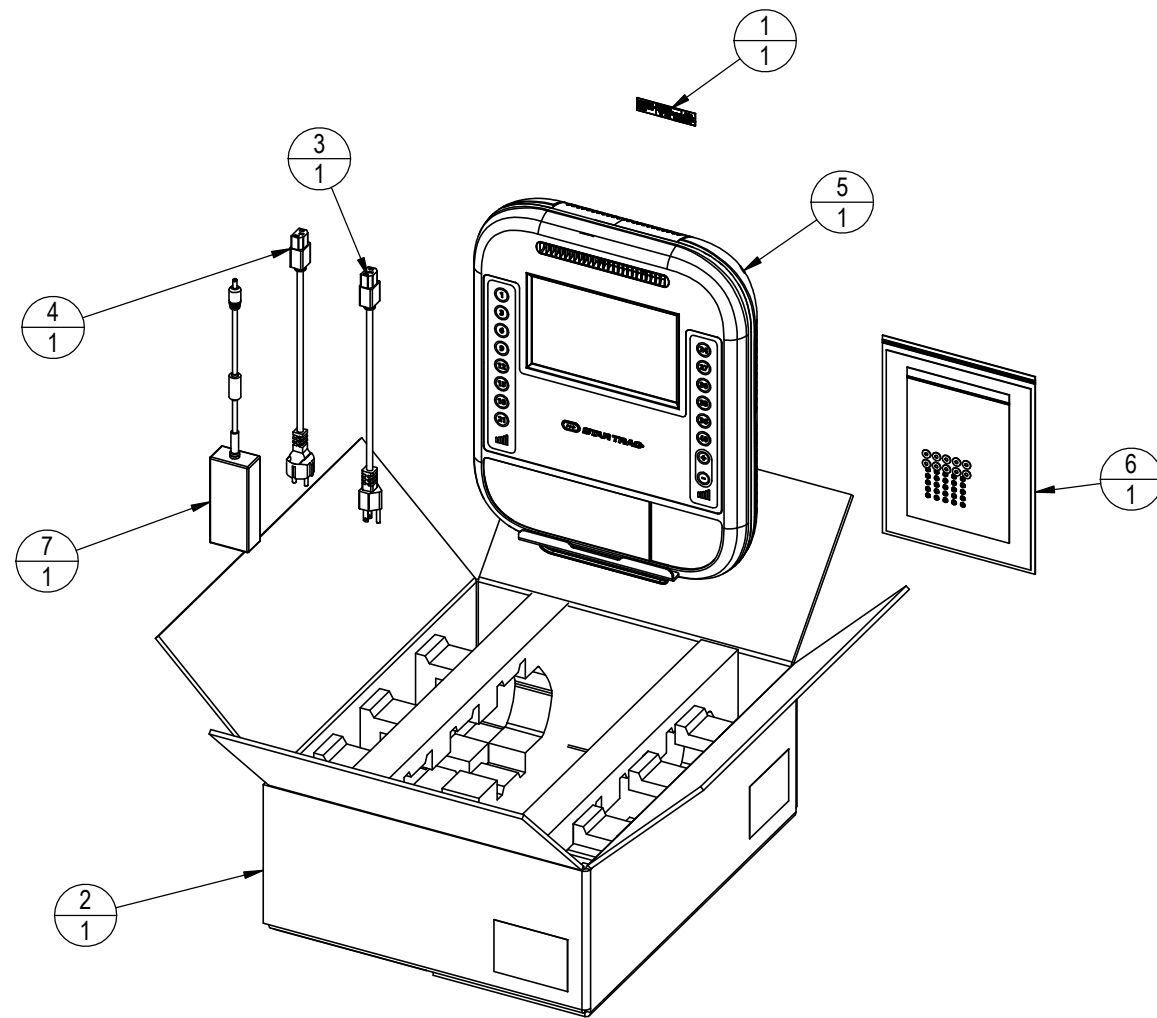

ITEM NO.	PART NUMBER	DESCRIPTION	
1	050-2191	LABEL, S/N DISPLAY	1
2	050-2380	PACKAGE, DISPLAY, BCS, GD3	1
3	220-0270	ADAPTER, CORD LINE, NEMA 5-15	1
4	220-0272	ADAPTER, CORD LINE, CEE 7/7	1
5	701-0411-XX	ASSY, DISPLAY, 10 IN EMBED, 4-BCS	1
6	701-0443	KIT, TOOLS & DOCS, 10 IN EMB, 4-SERIES	1
7	712-4022	POWER SUPPLY, 90-260VAC/12VDC 5A MIN	1

DOCUMENT STATUS:

NOTICE OF PROPRIETARY INFORMATION
 THIS DOCUMENT SHALL NOT BE REPRODUCED NOR SHALL THE INFORMATION CONTAINED HEREIN BE USED BY OR DISCLOSED TO OTHER EXCEPT AS EXPRESSLY AUTHORIZED BY CORE HEALTH & FITNESS, LLC.

CLASS OF WORK	UNLESS OTHERWISE SPECIFIED DIMS ARE IN mm. TOLERANCES FOR MEASURE OF LENGTH ARE:							ANGLES = ±2°
	0.5 to 3	>3 to 6	>6 to 30	>30 to 120	>120 to 400	>400 to 1000	>1000 to 2000	
FINE	±0.05	±0.05	±0.1	±0.15	±0.2	±0.3	±0.5	----
MEDIUM	±0.1	±0.1	±0.2	±0.3	±0.5	±0.8	±1.2	±2
COARSE	±0.2	±0.3	±0.5	±0.8	±1.2	±2	±3	±4
VERY COARSE	----	±0.5	±1	±1.5	±2.5	±4	±6	±8

MATERIAL
SEE BOM

FINISH
SEE NOTES

VENDOR:

P/N:

THIRD ANGLE PROJECTION

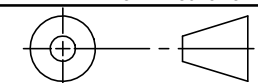

	INITIAL	DATE
DRAWN	ZDH	04/29/2020
CHECKED		
APPROVED		

CORE HEALTH & FITNESS, LLC

4400 NE 77th Ave., Suite 300
 Vancouver, WA 98662

CORE PART NO	REV
700-0507-XX	A
TITLE KIT, DISPLAY, 10IN TOUCHSCREEN, 4-CT/UB/RB	

SCALE: 1:10 SHEET 1 OF 1 SHEET SIZE: B

- NOTES:
1. USE NON MARKIING, LOW TACK, CLEAR TAPE TO HOLD BACK PLASTIC
 2. CLEAN MATING SURFACE WITH DENATURED ALCOHOL PRIOR TO ADHERING
 3. TORQUE TO 8-12 LBIN (0.9 - 1.4 Nm)
 4. APPLY PRESSURE FOR AT LEAST 5 SEC FOR ADHESIVE TO ADHERE TO PLASTIC SHROUD WHEN HR BOARD IS MOUNTED
 5. COLOR DESIGNATOR -XX SPECIFIED IN PARENT SKU, -XX COLOR PER SOP 622-200-112
 6. FLASH MODULE TO BE PROGRAMMED WITH THE LATEST VERSION OF SOFTWARE

REVISION HISTORY				
REV	DATE	DESCRIPTION	ECO	BY
A	4/29/2020	PRODUCTION RELEASE	20059	ZDH

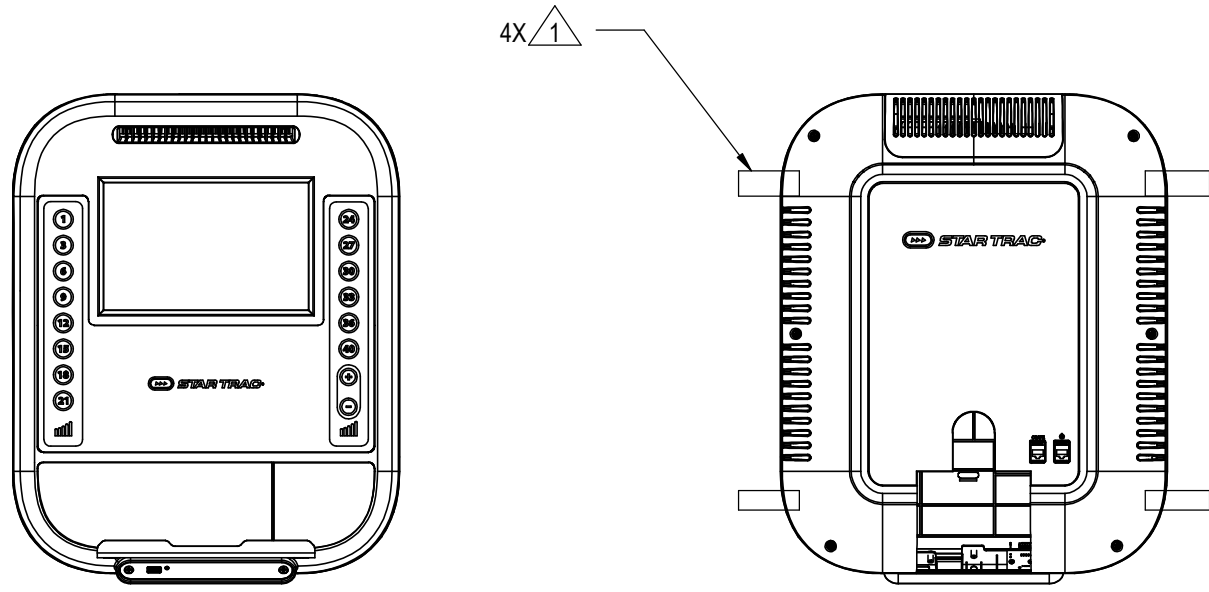

ITEM NO.	PART NUMBER	DESCRIPTION	QTY.
1	020-7435-XX	PLASTIC, DISPLAY, REAR, UPPER COVER, BCS	1
2	020-7440-XX	BRACKET, MAG RACK	1
3	020-7445-XX	PLASTIC, DISPLAY, FAN VENT	1
4	020-8015-XX	PLASTIC, DISPLAY, EMBED, 10", 4-SERIES	1
5	050-5617	KEYPAD, START, 4-CT	1
6	050-5743	KEYPAD, EMBED, 4-BCS	1
7	110-3163	SCREW, M3X0.5, 8mm, PHT, PH, CS, ZP, TC, GRD-10.9	14
8	110-3165	SCREW, #8-18, 1/2", HI-LOW, PHT, PH, CS, ZP-B	1
9	110-3402	SCREW, #8-18, 3/4", HI-LOW, PHT, PH, CS, BO	8
10	140-3771	FOAM GASKET, TOP, 4-SERIES	2
11	140-3772	FOAM GASKET, SIDE, 4-SERIES	2
12	240-6846	CONNECTOR, 8 PIN, INLINE	2
13	701-0027	ASSY, FAN ASSEMBLY	1
14	701-0245	CABLE, CSAFE	1
15	701-0246	CABLE, POWER, MYE RECEIVER	1
16	701-0328	ASSY, ENTERTAINMENT INSERT, BLANK, 4-TR	1
17	701-0329-XX	ASSY, USB PANEL, 4-TR	1
18	701-0332	ASSY, CABLE, WIRELESS HR, 4-TR	1
19	701-0333	BOARD, HEART RATE, 4-TR	1
20	701-0344-XX	KIT, DISPLAY, REAR, PLASTIC & DECAL, 4-CT	1
21	701-0357	CABLE, GROUNDING, 4-TR	1
22	701-0442	ELECTRONICS, DISPLAY, 10IN TS, 4-BCS	1
23	731-0584	SCREW, #8-18, 3/8", PHT, PH	4

DOCUMENT STATUS:

NOTICE OF PROPRIETARY INFORMATION
THIS DOCUMENT SHALL NOT BE REPRODUCED NOR SHALL THE INFORMATION CONTAINED HEREIN BE USED BY OR DISCLOSED TO OTHER EXCEPT AS EXPRESSLY AUTHORIZED BY CORE HEALTH & FITNESS, LLC.

CLASS OF WORK	UNLESS OTHERWISE SPECIFIED DIMS ARE IN mm. TOLERANCES FOR MEASURE OF LENGTH ARE:								ANGLES = ±2°
	0.5 to 3	> 3 to 6	> 6 to 30	> 30 to 120	> 120 to 400	> 400 to 1000	> 1000 to 2000	> 2000	
FINE	±0.05	±0.05	±0.1	±0.15	±0.2	±0.3	±0.5	----	
MEDIUM X	±0.1	±0.1	±0.2	±0.3	±0.5	±0.8	±1.2	±2	
COARSE	±0.2	±0.3	±0.5	±0.8	±1.2	±2	±3	±4	
VERY COARSE	----	±0.5	±1	±1.5	±2.5	±4	±6	±8	

MATERIAL
SEE BOM

FINISH
SEE NOTES

VENDOR: _____ P/N: _____

THIRD ANGLE PROJECTION		
	INITIAL	DATE
DRAWN	ZDH	04/29/2020
CHECKED		
APPROVED		

CORE HEALTH & FITNESS, LLC
4400 NE 77th Ave., Suite 300
Vancouver, WA 98662

CORE PART NO: **701-0411-XX** REV: **A**

TITLE: **ASSY, DISPLAY, 10 IN EMBED, 4-BCS**

SCALE: 1:8 SHEET 1 OF 3 SHEET SIZE: B

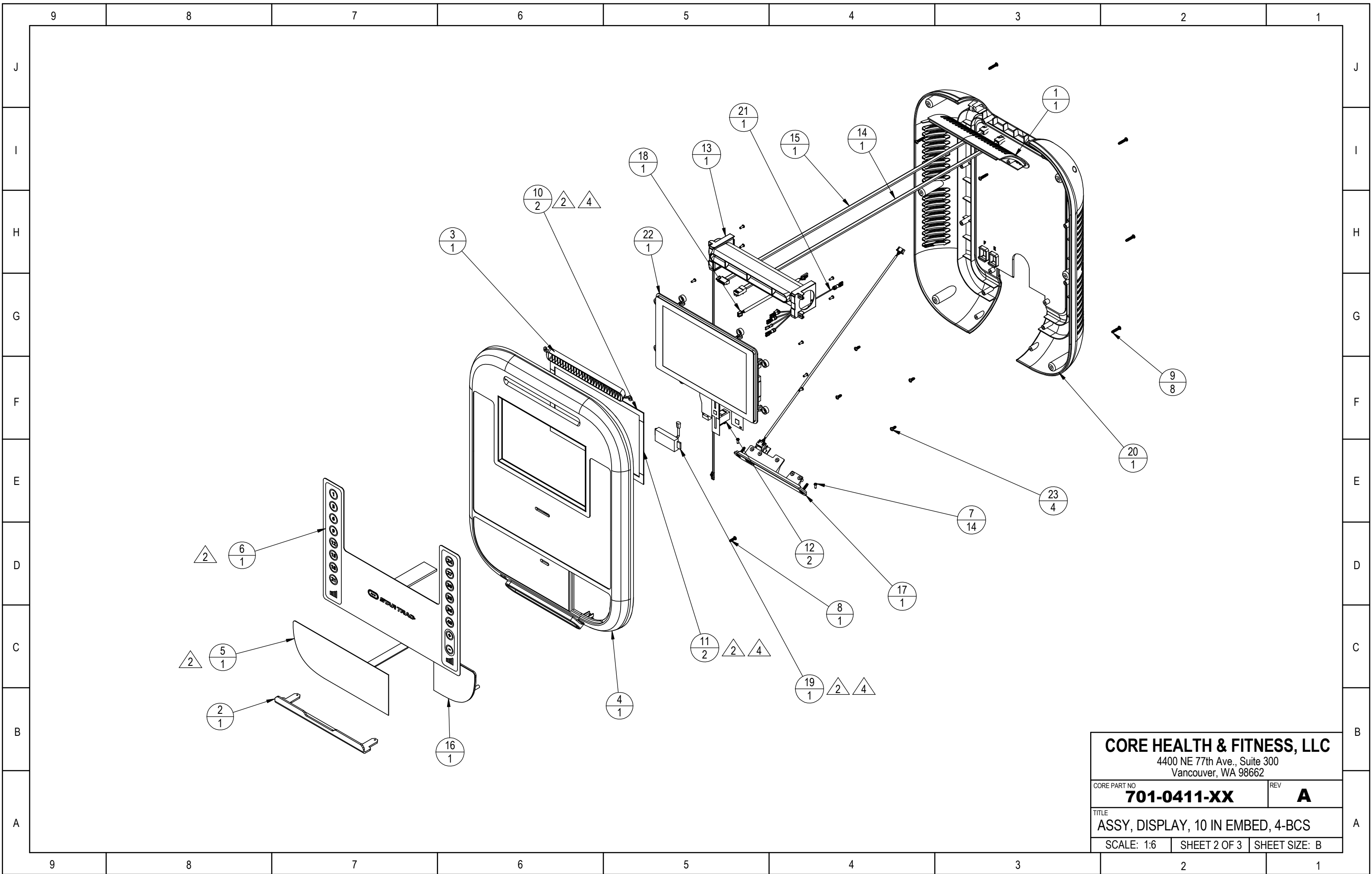

CORE HEALTH & FITNESS, LLC		
4400 NE 77th Ave., Suite 300 Vancouver, WA 98662		
CORE PART NO	701-0411-XX	REV A
TITLE ASSY, DISPLAY, 10 IN EMBED, 4-BCS		
SCALE: 1:6	SHEET 2 OF 3	SHEET SIZE: B

9 8 7 6 5 4 3 2 1

NOTES (cont'd.):

8. LABEL BOARD WITH IDENTIFICATION LABELS AT NOTED LOCATIONS

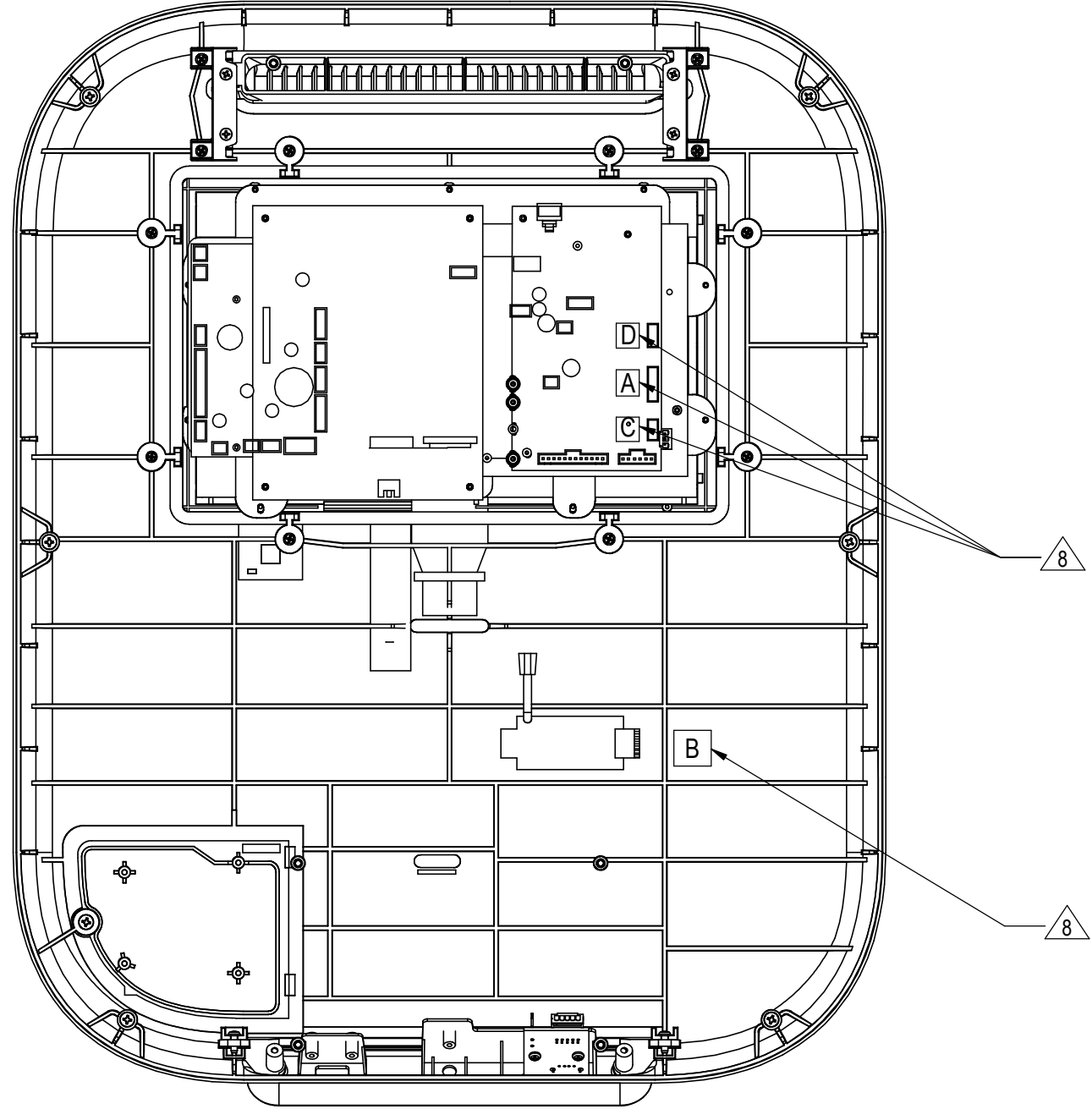

CORE HEALTH & FITNESS, LLC		
4400 NE 77th Ave., Suite 300 Vancouver, WA 98662		
CORE PART NO	701-0411-XX	REV A
TITLE ASSY, DISPLAY, 10 IN EMBED, 4-BCS		
SCALE: 1:3	SHEET 3 OF 3	SHEET SIZE: B

9 8 7 6 5 4 3 2 1